

# **Optimizing SCR Catalyst Design and Performance for Coal-Fired Boilers**

**Scot Pritchard  
Chris DiFrancesco  
Cormetech, Inc.  
Durham N.C  
(919) 620-3000**

**Shozo Kaneko  
Noriyoshi Kobayashi  
Mitsubishi Heavy Industries, Ltd.  
Nagasaki, Japan  
(045) 224-9178**

**Kohei Suyama  
Kozo Iida  
Mitsubishi Heavy Industries, Ltd.  
Nagasaki, Japan  
(958) 28-6401**

Presented at  
EPA/EPRI 1995  
Joint Symposium  
Stationary Combustion NO<sub>x</sub> Control

May 16-19, 1995

## OPTIMIZING SCR CATALYST DESIGN AND PERFORMANCE FOR COAL-FIRED BOILERS

Scot Pritchard  
Chris DiFrancesco  
Cormetech, Inc.  
5000 International Drive  
Durham, NC 27712

Shozo Kaneko  
Norihisa Kobayashi  
Mitsubishi Heavy Industries, Ltd.  
Yokohama, Japan

Kohei Suyama  
Kozo Lida  
Mitsubishi Heavy Industries, Ltd.  
Nagasaki, Japan

### **Abstract**

The design of an SCR system for a coal-fired application is a challenge due to particulate, catalyst poisons, and  $\text{SO}_2$  in the flue gas. Our experience show that coal-fired SCRs are successful when the system impact and catalyst deterioration factors are understood and specific countermeasure are implemented in system and catalyst design

There are several factors that the system and catalyst must consider in order to assure success. They include: type of boiler, required performance, fuel and ash analysis, ash loading, type of SCR, inlet conditions, Catalyst deactivation mechanisms and impact on down stream equipment.

This paper explains each system and catalyst deterioration factor that we have experienced. For each factor, it presents the specific countermeasure that has resulted in successful SCR systems. Also, it discusses the design of improved catalyst derived from our experience. Finally, two case studies illustrate the impact of optimized design.

## Introduction

Selective Catalyst Reduction (SCR) is recognized worldwide as the most effective NO<sub>x</sub> Control Technology for utility boilers and combustion turbines when substantial NO<sub>x</sub> reduction of 50% to 95% is required. In addition to its proven high performance, It has also become an economically viable solution, with current installed cost, in the United States, estimated at between \$20/kw for natural gas and \$50/kw-\$70/kw for coal units. The technology has even given some utilities the capability to achieve lower heat reduction or omission of flue gas recalculation (FGR).

Mitsubishi Heavy Industries (MHI) pioneered the developed and application of SCR technology starting in the late 70's in Japan, and installed the worlds' first High-dust SCR application on a 175 MW coal fired boiler in 1980. MHI transferred their technology through licensing agreement to several companies in Europe and to Cormetech in the United States. Over 319 units including 56 coal fired boilers worldwide operation successfully using this technology.

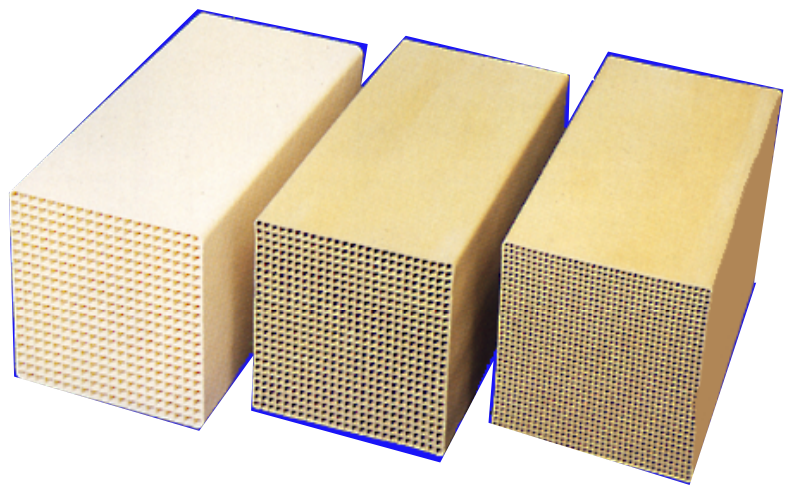

Figure 1  
Catalyst for Coal, Oil, and Gas Applications

Cormetech is a joint equity company of Corning Incorporated, MHI, and Mitsubishi Chemical Company (MCC). Cormetech design and Manufactures homogeneous Titanium-Tungsten-Vanadium (Ti-W-V), Extruded honeycomb catalyst for fossil-fuel-fired applications. Figure 1 show a photograph of catalyst for coal, oil, and gas applications. Cormetech draws upon the vast experience database of MHI, the extrusion and catalyst know-how of corning, and catalyst technology of MCC to provide an optimized product to the market.

This paper address the methods successfully implemented to design and optimize catalyst performance in coal fired boiler applications. The basics of deNO<sub>x</sub> catalysis are

reviewed in preparation for the discussion on system impact, catalyst deterioration, mechanism, and countermeasures that follows. Additionally, catalyst design optimization is presented by a discussion of improved catalysts for coal applications. Two case studies (pulverized coal and cyclone boilers) comparing conventional and improved catalyst are presented.

## Background of SCR Reaction

In coal fired boilers in which SO<sub>x</sub> is presented in the flue gas two chemical reaction that occur in the presence of the SCR catalyst are of most importance to the following discussion

One reaction, of course, is the deNO<sub>x</sub> reaction:



Figure 2 illustrates this primary reaction mechanism. Starting in the upper left-hand corner of the figure and proceeding clockwise is:

1. Active catalyst site (Me = metal)
2. Absorption of ammonia molecule
3. Reaction of NO with NH<sub>3</sub> forming
4. Regeneration of active site by oxidation

The second reaction is oxidation of sulfur dioxide:



The NO<sub>x</sub> conversion rate and SO<sub>2</sub> oxidation rate will partly depend upon the rate in which the reactants diffuse through the wall of the porous catalyst to reach active sites where reaction takes place. Through our experience we have determined the rate of chemical reaction is fast reaction for our catalyst. For deNO<sub>x</sub> conversion the rate of chemical reaction is fast relative to the rate of diffusion. Therefore the catalyst is effective primarily at the surface of the wall. On the other hand, the SO<sub>2</sub> oxidation chemical reaction rate is slow relative to the rate of diffusion so that the reactants diffuse into the entire wall. This conclusion is relevant to the subsequent discussion on the system impacts, catalyst deterioration mechanisms, and countermeasures.

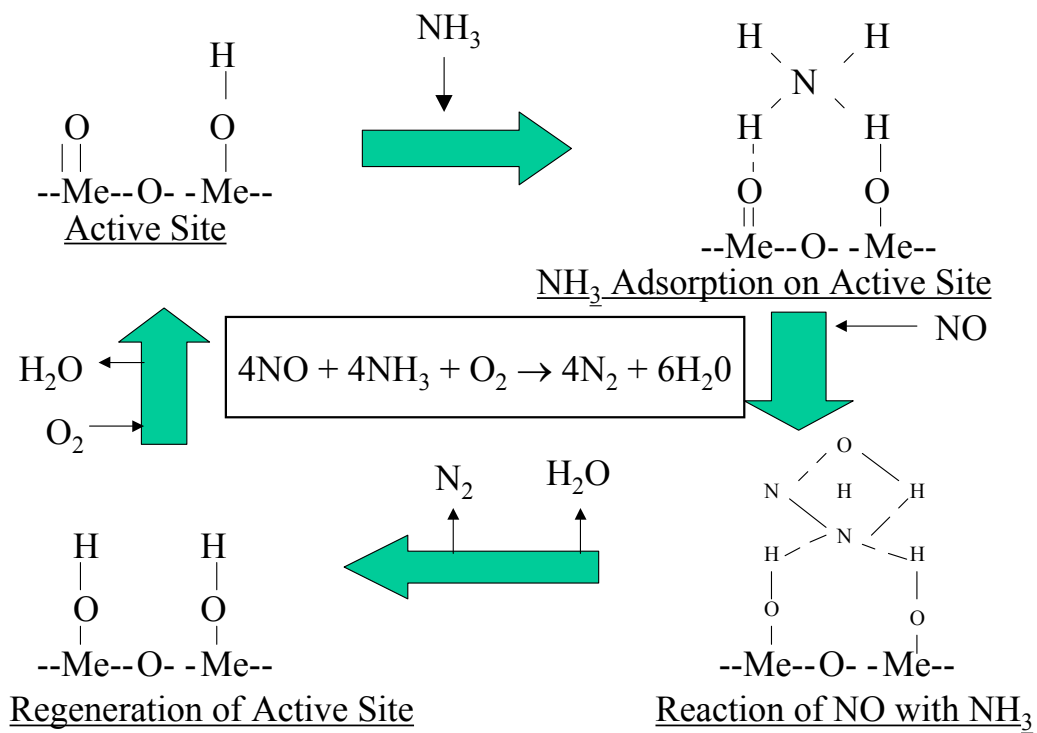

Figure 2  
SCR Surface Reaction Mechanism

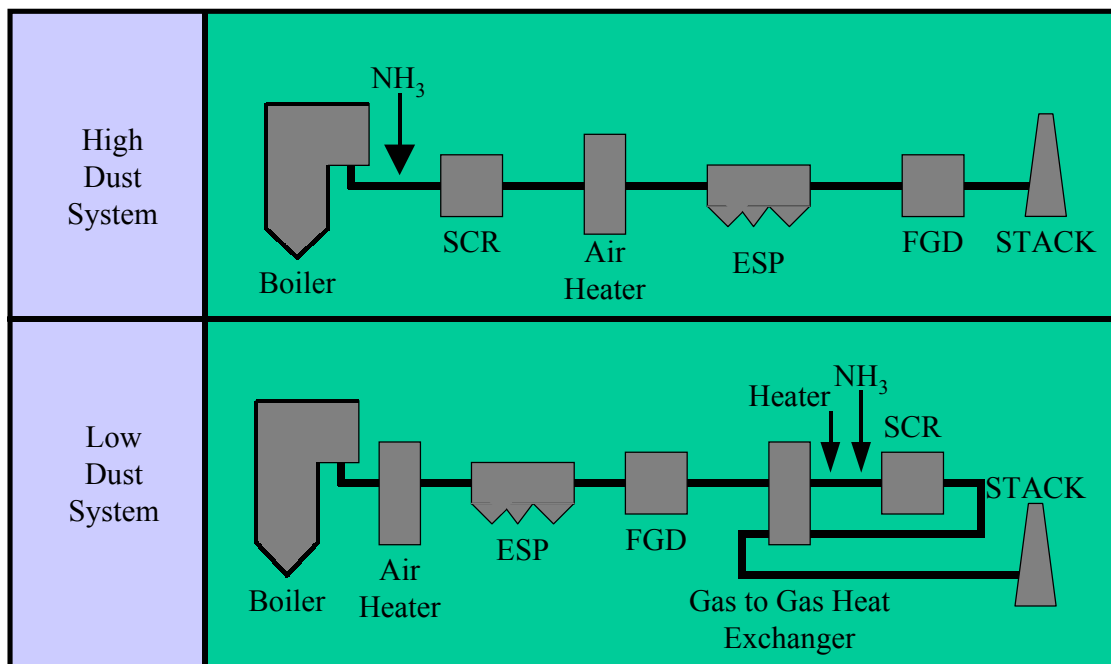

Figure 3  
SCR Configurations

## System Design Impact & Countermeasures

*Figure 3* shows two typical layout of SCR system applied to coal fired boilers. The Low-Dust or Tail End option shows the installation of the SCR reactor after the air preheater (APH), Electrostatic Precipitator (ESP), and flue Gas Desulfurization (FGD) systems. This option requires the flue gas to be reheated to acceptable SCR temperatures, typically 550<sup>0</sup>F-750<sup>0</sup>F. Low-Dust designs have primarily been used on wet bottom boilers which have ash re-circulation, due to concern over catalyst degradation caused by arsenic poisoning. The High-Dust option locates the SCR reactor between the economizer exit and the AOH inlet. This is more traditional for dry bottom boilers and less costly, and is now being applied to wet bottom boiler based on economics, advancements in catalyst resistance to arsenic poisoning, and limestone addition to the fuel, which will be discussed later.

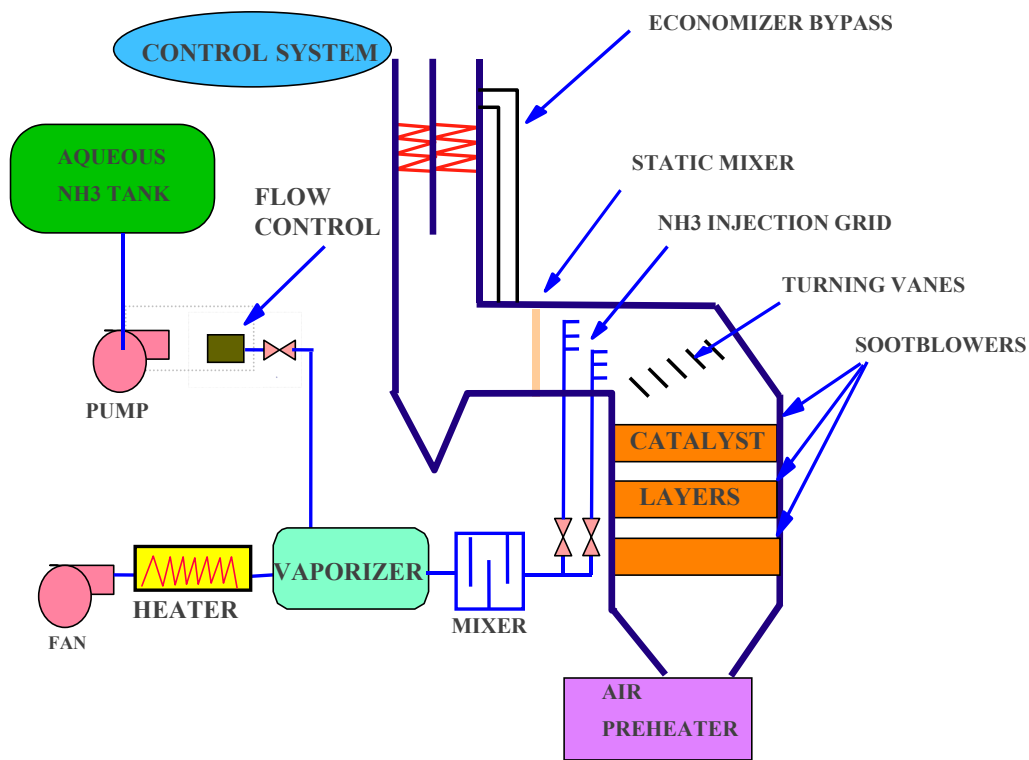

Figure 4  
SCR Components

The SCR system consists of many components in addition to the catalyst. *Figure 4* depict a high-dust SCR system which includes the catalyst reactor, economizer bypass used for part-load temperature control, static mixer used for temperature and/or ammonia mixing, turning vanes, ammonia vaporization system, ammonia injection grid (AIG), sootblower, and the control system. Since these components directly influence overall system effectiveness, Cormetech works closely with system equipment suppliers to ensure proper design.

Operational impact of an SCR system on coal fired boilers included drafts loss, SO<sub>3</sub> formation, and ammonia emission, Pressure drop is caused by the installation of the catalyst material in the flue gas and is typically minimized by expanding the flue gas path. Typical pressure value for conventional high dust applications range from 0.5 to 1 inch of water per catalyst layer, with 2-3 layers installed with an additional 1-2 inches for the components of the system.

As shown in equation (2) the SCR catalyst will convert a small amount of SO<sub>2</sub> to SO<sub>3</sub>. This conversion rate is typically less than 0.55 per layer depending upon the catalyst formulation, deNOx requirements, and operating temperature. If the SO<sub>2</sub> oxidation rate is too high, corrosion and plugging will occur in the (APH) due to the formation of H<sub>2</sub>SO<sub>4</sub> and NH<sub>4</sub>HSO<sub>4</sub>.

As a countermeasure, our catalyst is designed to achieve high deNOx activity while keeping SO<sub>2</sub> oxidation activity low. When considering the catalyst formulation, a high concentration of vanadium will result in a high deNOx activity, but will also result in a high SO<sub>2</sub> oxidation activity. One countermeasure to this is a vanadium concentration is selected such that there is sufficient deNOx activity with an acceptable level of SO<sub>2</sub> oxidation.

As a system countermeasure, the cold end surface of regenerative-type APH may be enameled and/or sootblowing capabilities may be enhanced.

Ammonia slip may contaminate flyash, and combination with SO<sub>3</sub> caused (APH) plugging. Designers can combat the effect by considering:

- 2ppm to 5ppm NH<sub>3</sub> slip at end-of-life
- ammonia injection grid with adequate representative NOx input value to control system
- multi-point outlet NOx sampling control grid to assure representative NOx input value to control system.
- permanent measuring grid for AIG tuning to assure proper distribution of ammonia
- Flyash ammonia concentration monitoring.

### **Catalyst Deterioration Mechanisms & Countermeasures**

When designing for a given application, designers must carefully review fuel And ash constituents (*see Table A*). Under ideal conditions the catalyst will reduce NOx for an unlimited period of time. (*Table B*) lists the primary deterioration mechanisms versus the type of coal fired units, wet or dry bottom.

Ash Moisture, %	6-33
Total Sulfur in Coal, %	0.6-1.6*
Trace Material, ppm	
Ni	3-40
Cr	7-46
As	1-25
Cl	41- 1,900
Ash analysis, %	
Si O <sub>2</sub>	41-71
As <sub>2</sub> O <sub>3</sub>	2-33
Fe <sub>2</sub> O <sub>3</sub>	2.5-10
CaO	2.4-26
MgO	0.7-49
TiO <sub>2</sub>	0.1-1.8
MnO	0.02-0.2
V <sub>2</sub> O <sub>5</sub>	0.01-0.1
Na <sub>2</sub> O	0.05-1.6
K <sub>2</sub> O	0.1-4.0
P <sub>2</sub> O <sub>6</sub>	0.06-1.3
SO <sub>3</sub>	1.6-16.5

**\*Application Experience on Oil up 5.4% Sulfur**

Table A  
Typical Fuel/Ash Composition

Boiler Type	Wet Bottom	Dry Bottom
Sintering	Negligible	Negligible
Accumulation of Alkaline Metal	Small	Small
Accumulation Earth Metal Masking	Large	Large
Accumulation of Arsenic Oxide	Large with Ash Re-circulation	Moderate
Flyash Deposition*	Small	Small
Erosion*	Small	Small

\*Highly dependent on proper design of SCR system

Table B  
Main Causes of Catalyst Deterioration

Based on a sound understanding of the deterioration mechanisms, specific countermeasures are implemented, such as:

- ◆ system design evaluation.
- ◆ catalyst formulation.
- ◆ catalyst volume selection.
- ◆ catalyst geometry.
- ◆ catalyst macro and micro pore design.
- ◆ catalyst characterization testing and predictive tools.

### Thermal Sintering

Thermal sintering is the growth of primary catalyst particle resulting in a reduction of catalyst surface area, which reduces catalyst performance. *Figure 5* illustrates this mechanism. Thermal stability is maximized with the corporation of Tungsten in the catalyst formulation. As a result, sintering is negligible at normal SCR operating temperatures.

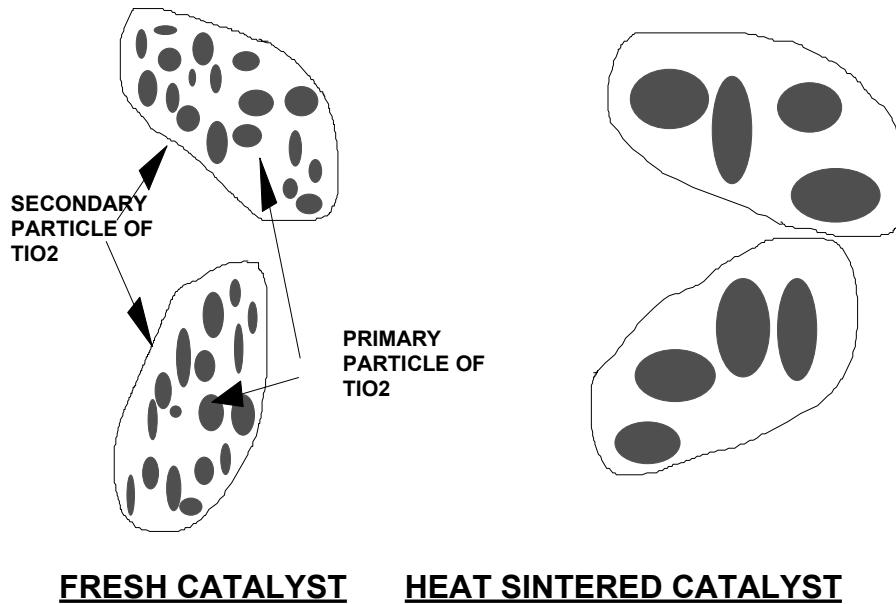

Figure 5  
Thermal Sintering

### Alkaline Metal (Na, K)

Alkaline metal may directly react with active sites and render them inert as shown in *Figure 6*. Since the deNox reaction takes place primarily on the surface, the degree of deactivation depends on the surface concentration of the alkaline metals. In a water-soluble form, these alkaline metals are highly mobile and will migrate throughout the catalyst material. Since the wall of our catalyst consists entirely of catalyst material, the surface concentration of alkaline metal is diluted by this migration, minimizing the deactivation rate.

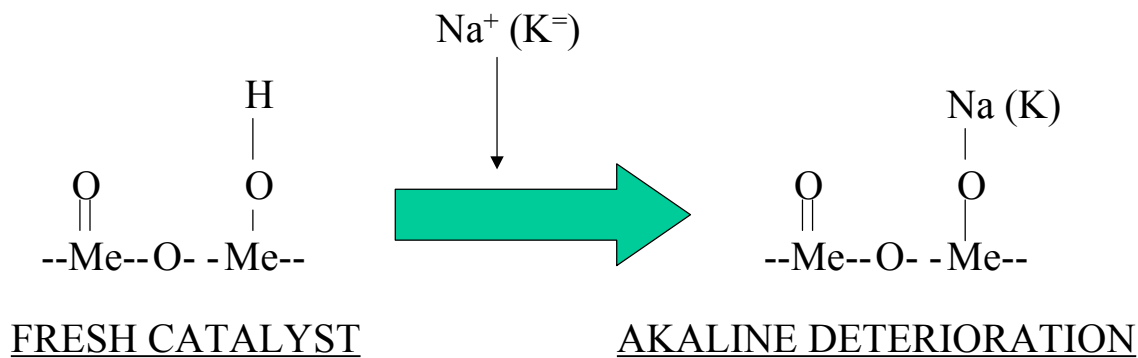

Figure 6  
Alkaline Deterioration Mechanism

For the subject catalyst in coal-fired applications, it is our experience that this type of poisoning has a small impact, since most of the alkaline metals in the coal ash are not water soluble. The impact is larger in oil-fired applications where the majority of the alkaline metals in the ash are water-soluble or when the thickness of the catalyst material is low. For example, given the same concentration of alkaline metals in the flue gas, this catalyst will have a lower surface poison concentration than a coated product and, thus, have a lower deactivation rate and longer useful life as shown in [Figure 7](#).

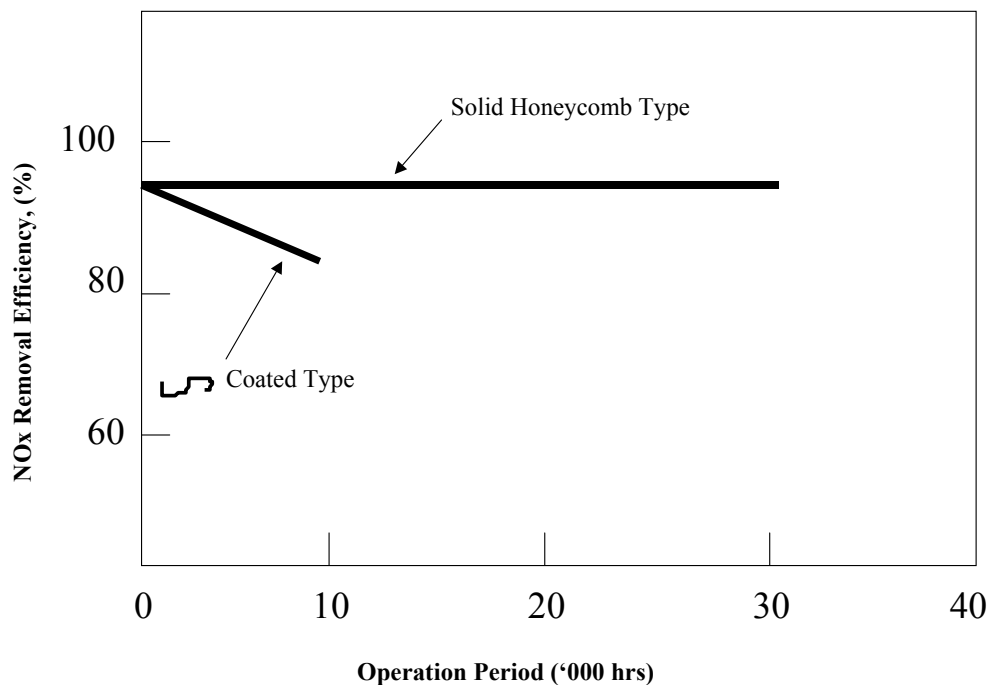

Figure 7  
Comparison of Durability (Oil Firing)

## Arsenic (As)

Arsenic poisoning is caused by gaseous arsenic  $As_2O_3$  in the flue gas. The  $As_2O_3$  diffuses into the catalyst and solidifies on both active and non-active sites, as shown in [Figure 8](#).

As with alkaline metals, arsenic poison is best abated by use of homogenous catalyst compositions, which effectively reduce the surface poison concentration. Since the mechanism of arsenic poisoning is more diffusion-limited and subject to capillary condensation, optimized catalyst pore structure also lessens its effects. Further, engineers use accumulation rates determined by both lab and field tests to ensure a proper catalyst volume is provided for each specific application.

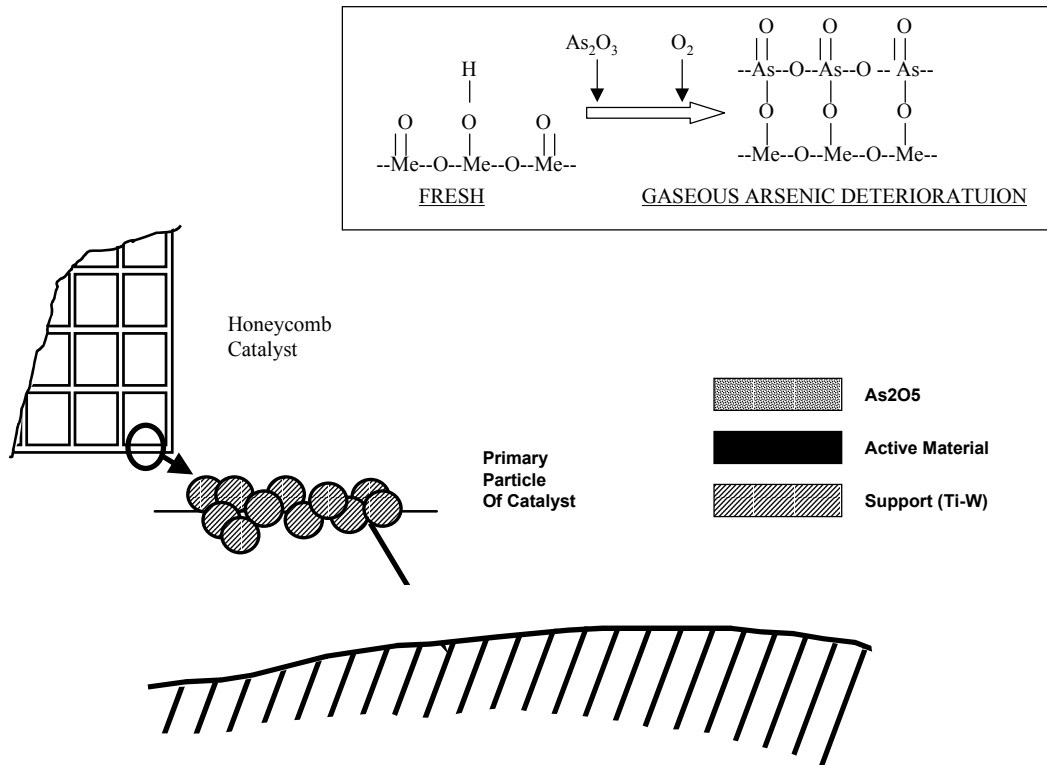

Figure 8  
Model of Arsenic Compound Accumulation

A system countermeasure incorporates the use of a fuel additive. As mentioned previously, wet bottom boiler with 100% ash recalculation present a worst case scenario for catalyst deterioration caused by arsenic poisoning. In order to combat the high levels of gaseous arsenic ( $As_2O_3$ ) in cyclone boilers, limestone may be added to the fuel. A typical limestone to fuel ratio is approximately 1:50. [Figures 9a, 9b, and 10](#) show how the addition of limestone effectively reduces gaseous arsenic at the entrance to the catalyst. The free  $CaO$  in the limestone reacts with arsenic, forming a solid,  $Ca(AsO_4)$  that will not poison the catalyst. The impact of adding limestone will be addressed further in the wet bottom boiler case study.

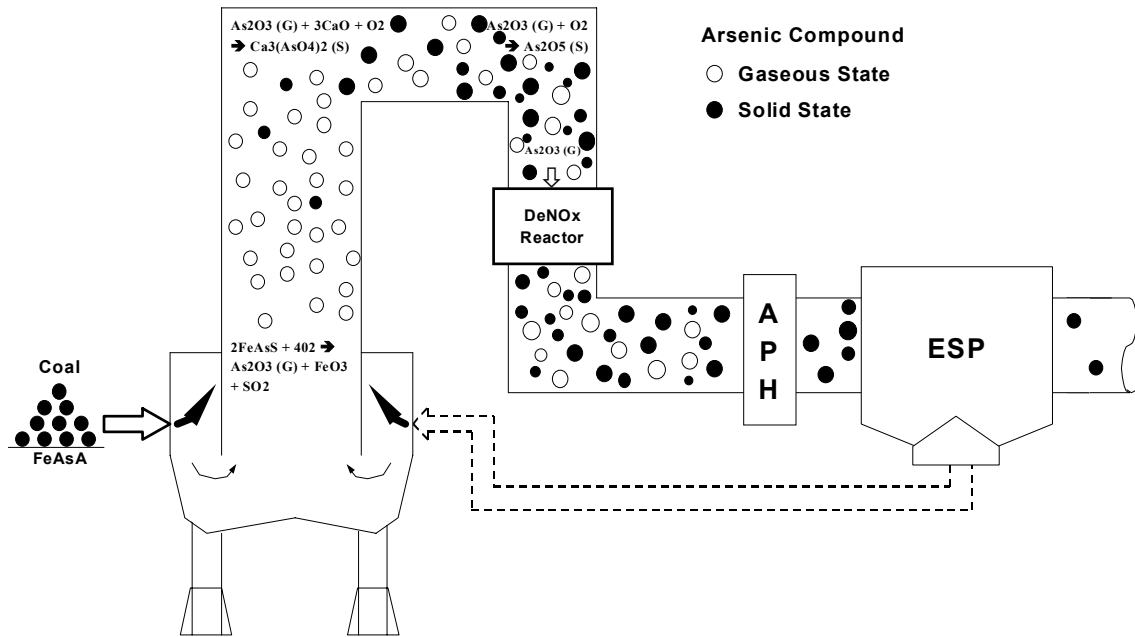

Figure 9a  
Arsenic Compound in Flue Gas

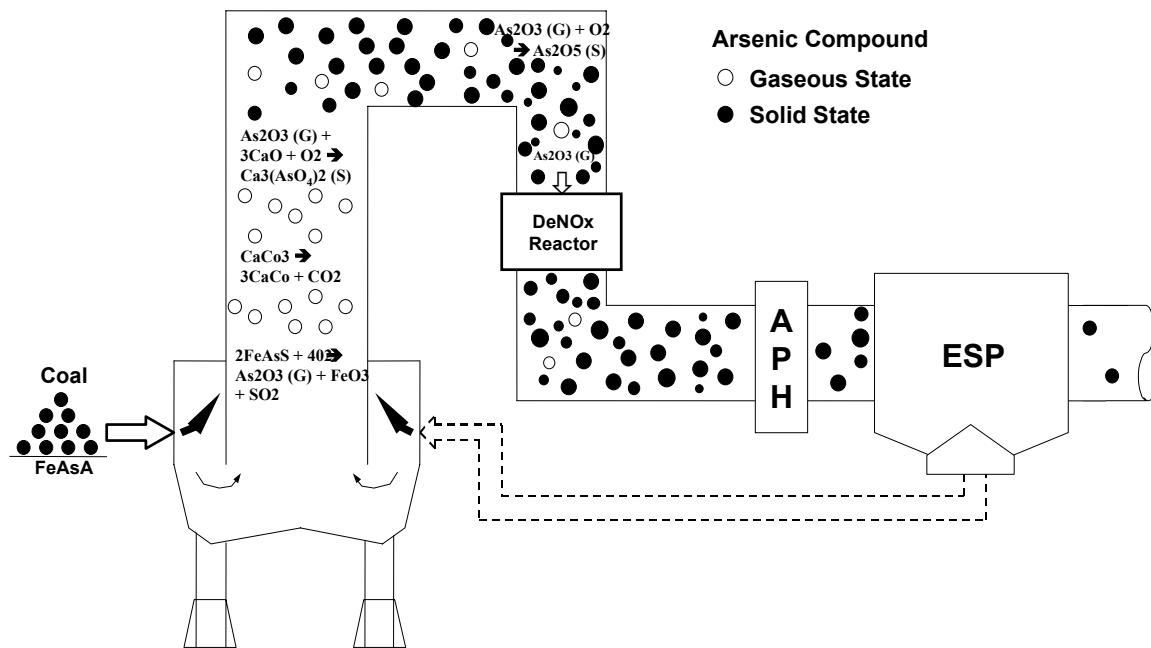

Figure 9b  
Effect of Limestone Injection

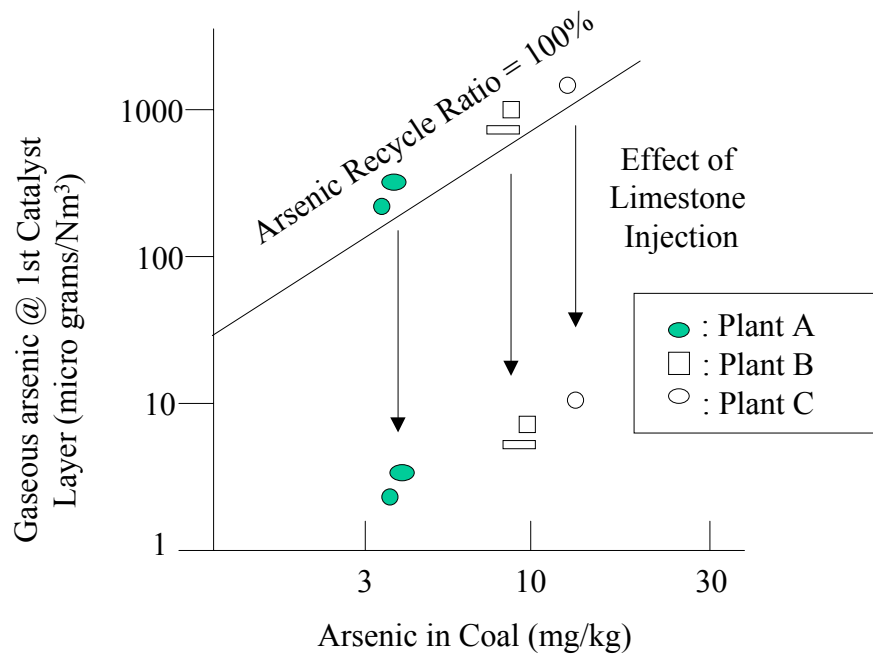

Figure 10  
Relationship Between Arsenic in Coal and Gaseous Arsenic

### Alkaline Earth Metals (Ca)

Alkaline earth metal poisoning primarily occurs when free CaO in the flyash reacts with SO<sub>3</sub> adsorbed on the catalyst surface forming CaSO<sub>4</sub>. The CaSO<sub>4</sub> may cause catalyst surface masking, preventing the reactants from diffusing in to catalyst surface masking, preventing the reactants from diffusing into catalyst. *Figures 11 and 12* illustrate this mechanism.

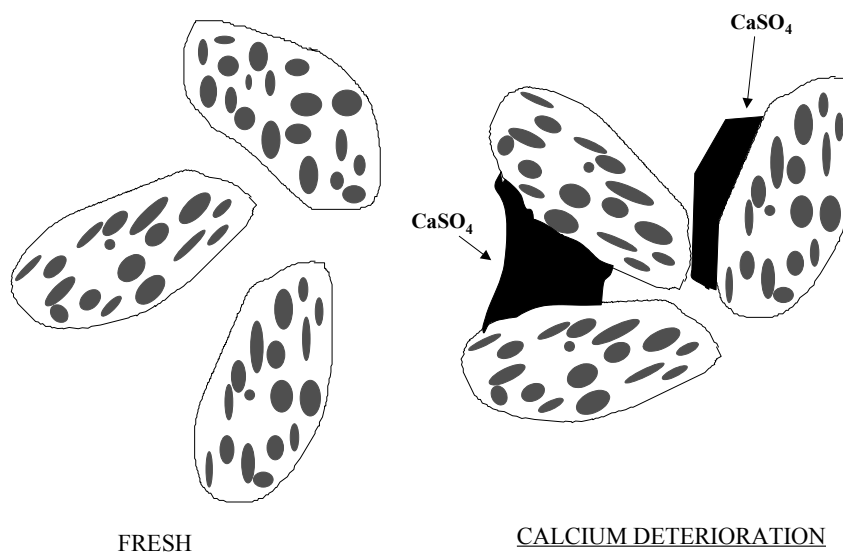

Figure 11  
Mechanism of Calcium Deterioration

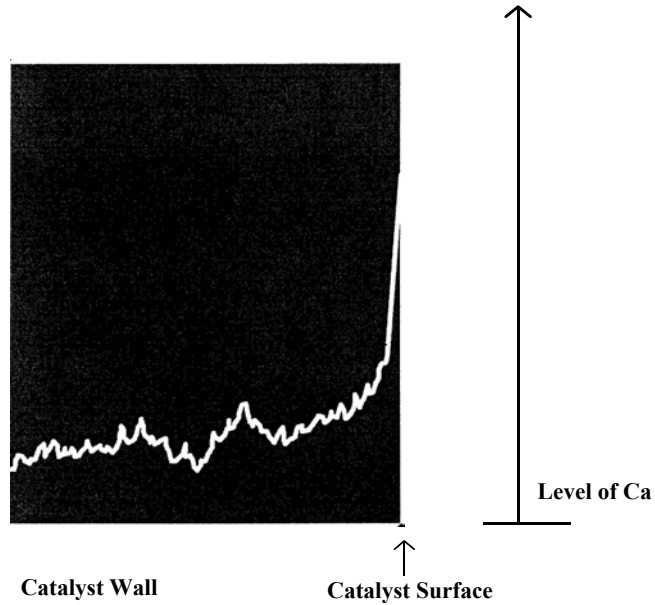

Figure 12  
Accumulation of calcium Composition in Catalyst

In order to address masking, particularly in dry bottom boilers where the free CaO content is nearly double that wet bottom boiler (see [Figure 13](#)), characterization of the mechanism and accurate prediction of deactivation rates is employed. Experience shows that quantity of free CaO in the fly ash governs the amounts of deactivation. Extensive modeling of deactivation from full scale and laboratory data has been development providing high confidence in design to counter this phenomenon.

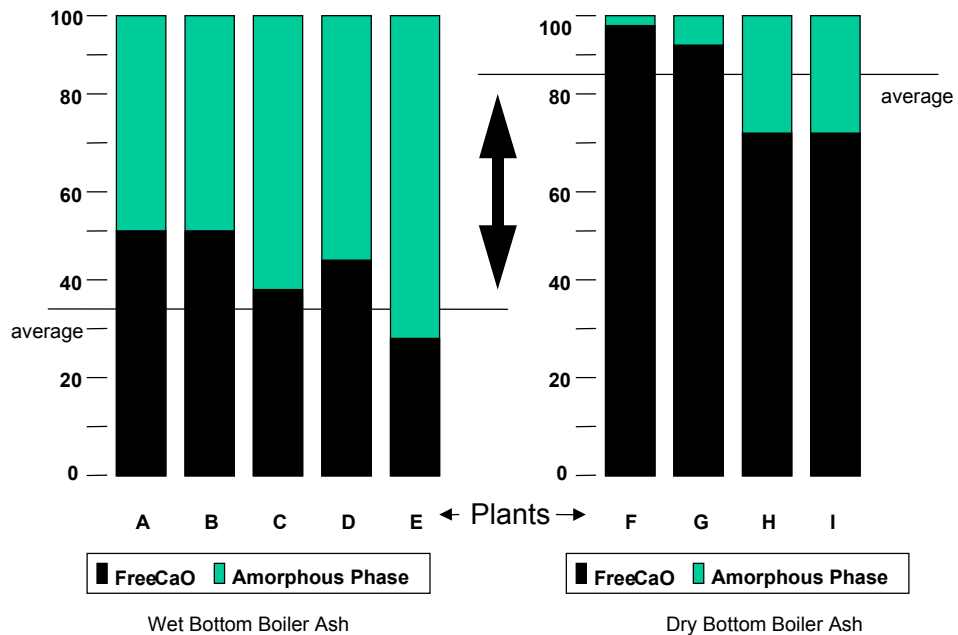

Figure 13  
Free CaO Ratio in Fly Ash

## Catalyst Plugging

Catalyst plugging has two primary causes: (a) ammonia salt deposition and (b) flight deposition. Proper selection of catalyst pitch and cell opening size minimizes plugging. Good system design is also a primary prevention tool.

Ammonia salt formation/deposition will not occur provided the SCR inlet temperature maintained above the salt formation level. Typically temperature maintenance is only a problem during part load operation and is elevated by installing a water- or gas-side economizer bypass in the system. If a gas bypass is used, careful attention must be paid to provide adequate temperature mixing upstream of AIG. This avoids low temperature streamline, which can cause localized salt formation at the AIG and catalyst.

Flight deposition is minimized through proper flow distribution across the catalyst face. This accomplished through engineering of SCR system flue layout, Computational Fluid Dynamics (CFD) codes, and/or cold flow modeling.

The design limit the number of areas where dust accumulation may occur, i.e.,

- Avoiding flat surface as long leading edge to turning vanes.
- Installing as deflection devices on support beam flanges and sootblower pipes.
- Avoiding flue dead between dampers where ash accumulation may occur in closed position and exhaust onto catalyst when opened, etc.

## Erosion

Catalyst erosion is caused by the impingement of flyash on the catalyst face. Catalyst erosion is a function of gas velocity, ash character, angle of impingement, and catalyst properties. Cormetech has experience with flyash loading as high as 30g/Nm<sup>3</sup> and flue gas velocities up to 6.2 m/s.

Experience has proven that no significant erosion will occur with proper system design, catalyst material durability, and catalyst edge hardening. Poor flow and ash distribution at the inlet to the catalyst has been the source of most problems, and has improved significantly over the entire SCR experience history. Careful attention must be paid to utilize flow modeling (CFD and cold flow rectifier grid should be installed to straighten flow into the catalyst bed. Since most catalyst erosion occurs at the catalyst leading edge, which is exposed, to the direct impingement of dust particle the catalyst may also be hardened at the entrance region to provide further protection as shown in [Figure 14](#).

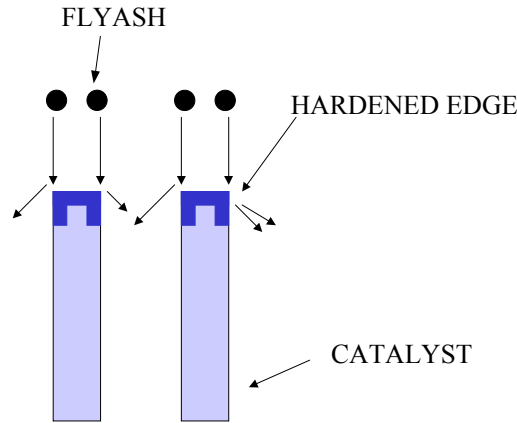

Figure 14  
Honeycomb Catalyst with Hardened Edge

Although in most cases In-Duct SCR is not attractive due to extremely high system draft loss and difficulty in control of gas flow and ammonia distribution, some utility site are considering the concept due to site plan limitations. Therefore, we will pilot test our hardened edge catalyst at velocities > 12m/s in 1995.

### Catastrophic Failure of SCR Catalyst

Catastrophic Failure is defined as sudden and permanent loss of catalyst performance based on our experience, catastrophic failure are extremely rare. The primary cause is associated with the ignition of ash buildup. The intense heat of a fire can irreversibly damage any SCR catalyst. Cormetech's ceramic honeycomb catalyst, unlike plate catalyst with stainless steel mesh substrates, will not promote oxidation; therefore fires are less likely to spread and are more easily contained.

### Coal Catalyst Developments

Based on our understanding of reaction and deactivation mechanisms we are improving our catalyst. The objective is to increase the deNOx reaction rate without increasing the SO<sub>2</sub> oxidation rate. One method is to modify the pore structure of the catalyst wall in order to reduce diffusion resistance. The other is novel method and requires further explanation.

Since the deNOx reaction is only effective at the surface, we have developed an improved catalyst of the same composition as our conventional catalyst with the exception that the vanadium is preferentially distributed to the surface of the catalyst wall. In this manner, we can maximize the concentration of vanadium in the effective fraction of the wall, maximizing deNOx activity without incurring high SO<sub>2</sub> oxidation.

Figure 15 shows the performance of this improved catalyst compared to that of conventional catalyst. Since the product is still made entirely of catalytic material, resistance to poisons is maintained.

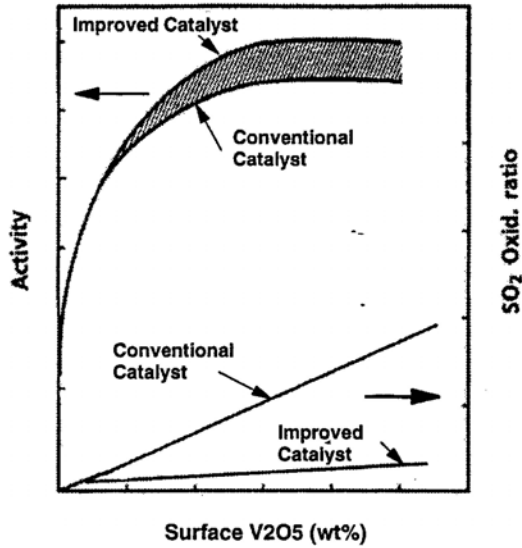

Figure 15  
Comparison of Catalyst Performance

### Development and Qualification of Improved Coal Catalysts

We are developing the improved coal catalyst described according to the schedule shown in [Figure 16](#).

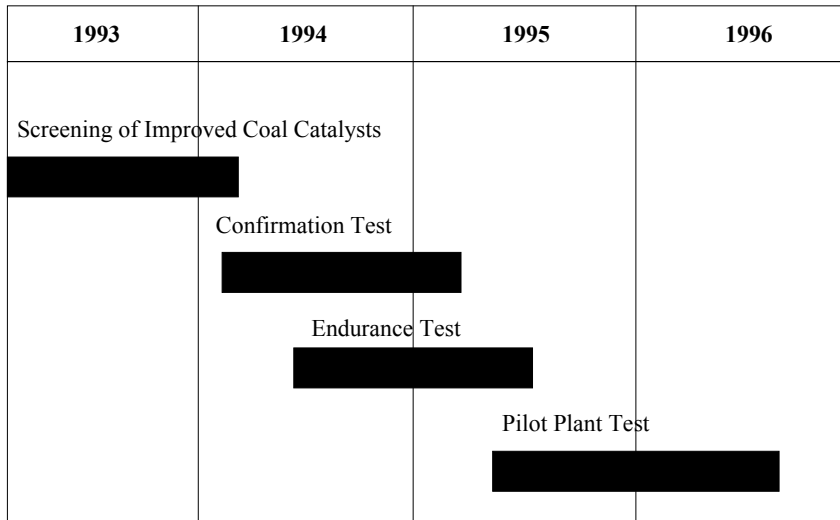

Figure 16  
Improved Coal Catalyst R&D Schedule

We have already completed laboratory performance confirmation and durability tests. The performance of the improved catalyst is approximately 15% higher than our conventional catalyst, without impact on SO<sub>2</sub> oxidation.

We have tested durability to gaseous arsenic poisoning by an accelerated method using the apparatus in *Figure 17*. The test results are shown in *Figure 18*. The improved catalyst maintains its performance advantage over conventional catalyst at any arsenic poisoning level.

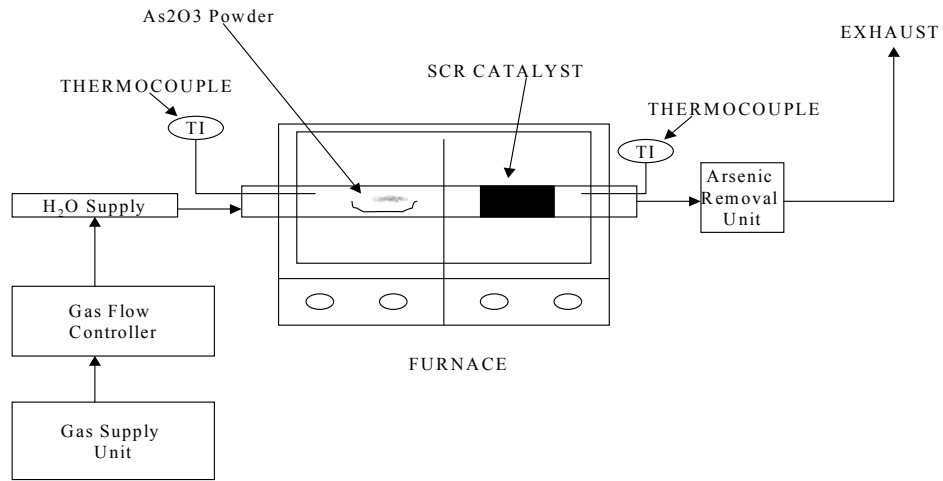
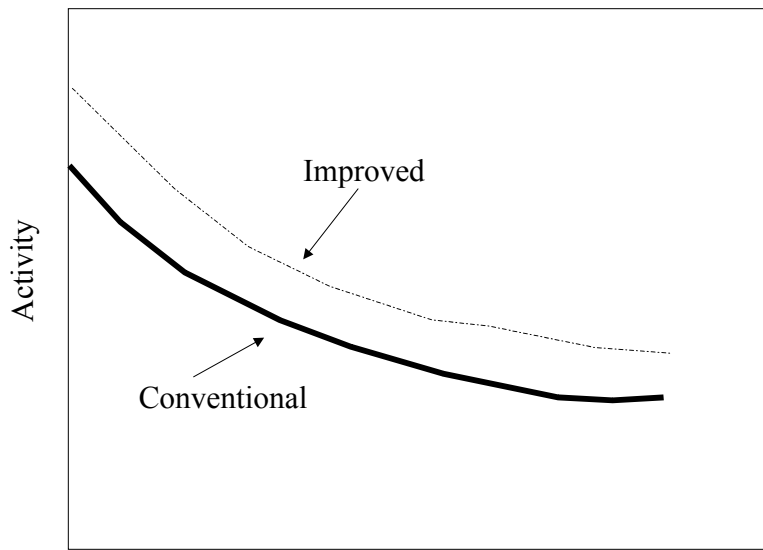

Figure 17  
Schematic of Arsenic Testing Apparatus



Arsenic Load, ppm\*hr  
Figure 18  
Arsenic Durability

Since the degree of Deactivation due to surface masking by  $\text{CaSO}_4$  is dependent only on the fraction of surface masked we expected that the rate of deactivation is the same for both conventional and improved catalyst. Therefore, given the same installed catalyst volume, the improved catalyst will maintain field performance much longer due to the higher initial activity, as shown in Figure 19.

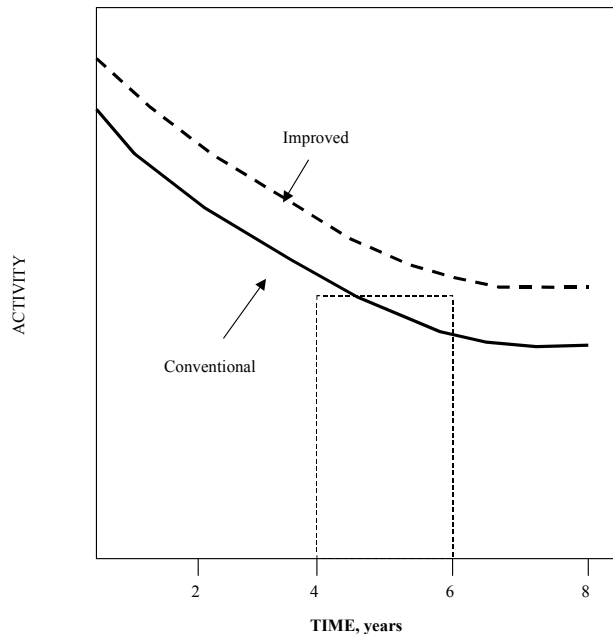

Figure 19  
CaO Durability

Before Commercialization, the endurance of the catalyst will be confirmed by operation in actual plant. Initial endurance tests will start by charging catalyst samples into commercial SCR plants in Japan. During 1995 catalyst samples will be charged into a coal unit in the United States and three coal units in Germany. The performance of the catalyst sample after aging in the commercial plants will be compared to fresh performance in order to evaluate endurance.

### **Impact of Improved Coal Catalyst on SCR Design for Coal Fired**

Whether achieving an increase in performance by optimizing the pore structure of the catalyst on the SCR design, two SCR case studies are described below comparing improved with conventional catalyst.

## Case Study 1: Dry Bottom Boiler

A 250 MW unit is selected as an example unit. *Table C* shows the design data for this unit. *Figure 20* shows the 10-year catalyst volume of the improved catalyst is higher by 15%; the catalyst volume of the improved catalyst is decreased by approximately 15% from the conventional catalyst volume.

Design Condition;	
Fuel	Coal
Plant Output, MW	250
Flue Gas FlowRate, Nm <sup>3</sup> /hr	784,000
NOx inlet, ppmvd @ 3% O <sub>2</sub>	154
NOx outlet, ppmvd @ 3% O <sub>2</sub>	31
NOx Removal Efficiency, %	80
Ammonia Slip, ppmvd @ 3% O <sub>2</sub>	5
Specification:	
Type of System	SCR
Type of Reactor	Vertical Flow-Fixed Bed
Type catalyst	Honeycomb
Number of reactor	1

Table C  
Dry Bottom Boiler

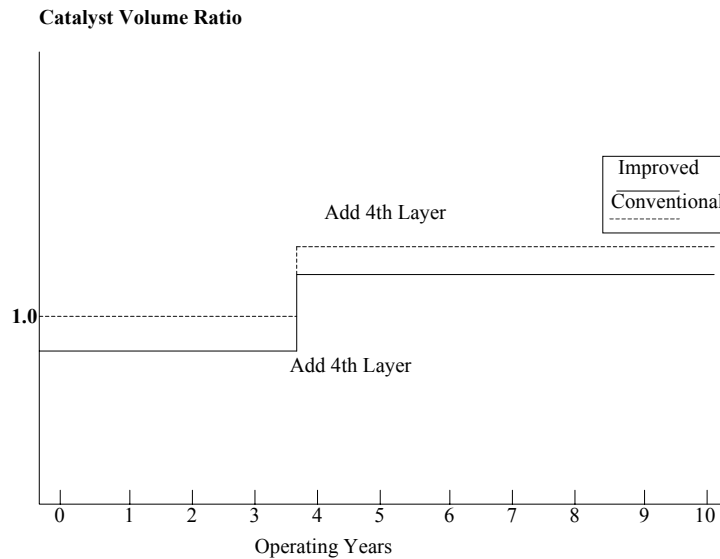

Figure 20  
Impact of Improved Catalyst  
Dry Bottom Boiler

## Case Study 2: Wet Bottom with Ash Recalculation

A 320 MW unit is selected as an example unit. *Table D* shows data for this unit. *Figure 21* shows the 10 years catalyst management plan. The total catalyst volume of the improved catalyst for ten years of operation is two-thirds that of the conventional catalyst. The impact on the catalyst management plan is shown in *Figure 22*. With Limestone Injection, the need for addition and replacements of catalyst are significantly delayed.

Design Condition	Coal
Fuel	320
Plant Output, MW	1,125,000
Flue Gas Flow Rate, Nm <sup>3</sup> /hr	1,652
NOx Inlet, ppmvd @ 3% O <sub>2</sub>	530
NOx removal efficiency, %	68
Ammonia Slip, ppmvd @ 3% O <sub>2</sub>	5
Flash recalculation Rate, %	100
Specification:	
Type of System	SCR
Type of Reactor	vertical flow-fixed bed
Type of Catalyst	honeycomb
Number Of Reactors	1

Table D  
Wet Bottom Boiler

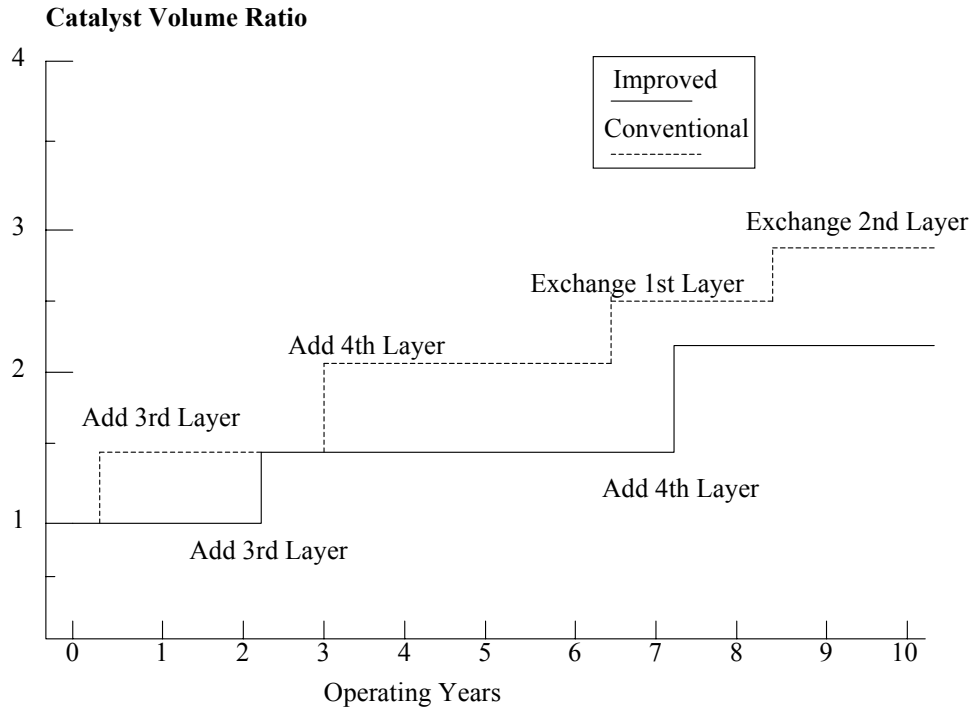

Figure 21  
Impact of Improved Catalyst  
Wet Bottom Boiler

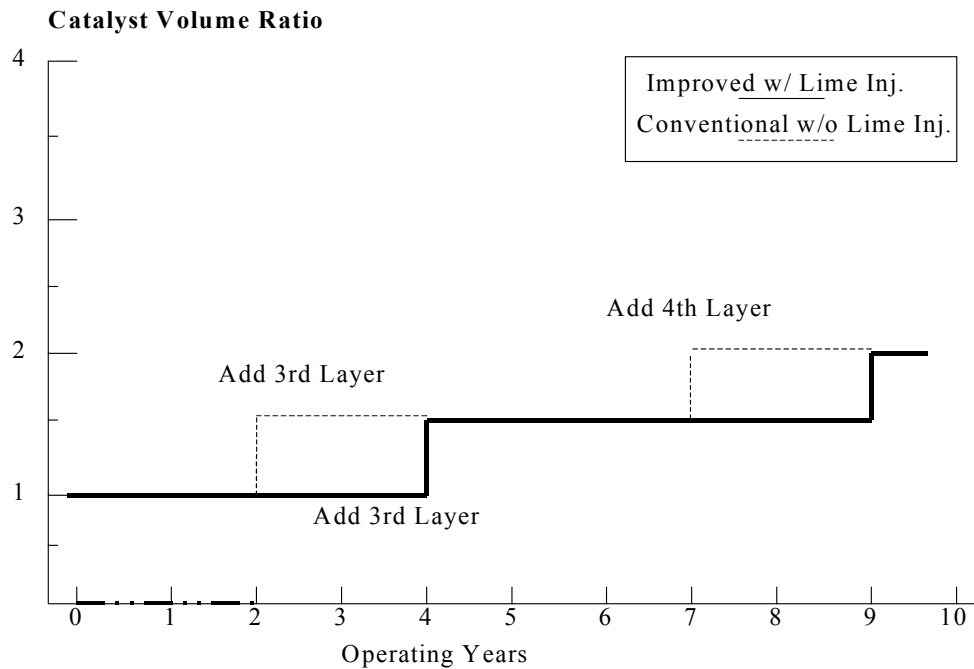

Figure 22  
Impact Of Limestone  
Wet Bottom Boiler

## **Conclusions**

Our experience shows that coal-fired SCRs are successful when proper attention is paid to system and catalyst design.

Proper system design is crucial to Maximizing Catalyst performance potential and achieving lowest annualized cost.

By exploiting the experience and know-how gained on existing facilities it is possible to further optimize catalyst design.